



Vacuum Box - 25 Yard

280-2500 / Vacuum Box - 25 Yard

280-2520 / Dewatering Vacuum Box



Standard Features

- **Floor:** 1/4 PL one piece
- **Crossmembers:** 3 x 4.1 channel 12" on center
- **Walls/Roof:** 1/4 PL solid welded, inside liner hooks
- **Structure:** Tubing and formed channel supports rated to operate at 30" HG
- **Door:** 1/4 PL with tubing frame
- **Front:** 1/4 PL with push plates
- **Pick Up:** Standard cable with 2 x 6 x 1/4 rails, gusset at each cross member
- **Wheels:** 4 each 10 dia x 9 long with grease fittings
- **Door Latch:** 4 independent ratchet blinders with chains, vertical 2nd latch
- **Gaskets:** Extruded rubber seal with metal retainers
- **Welds:** All welds continuous except substructure crossmembers
- **Finish:** Coated inside & out with direct to metal, rust inhibiting acrylic enamel color coat
- **Hydrotesting:** Full capacity static test
- **Dimensions:** 22'-11" long (21'8" inside), 94" wide (83" inside), see drawing for height
- **Options:** Steel grit blast & special paint, ampliroll, heil and dino pick up



Vacuum Box - 25 Yard

280-2500 / Vacuum Box - 25 Yard

280-2520 / Dewatering Vacuum Box

Vacuum Box / 280-2500 Mechanical Dimensions

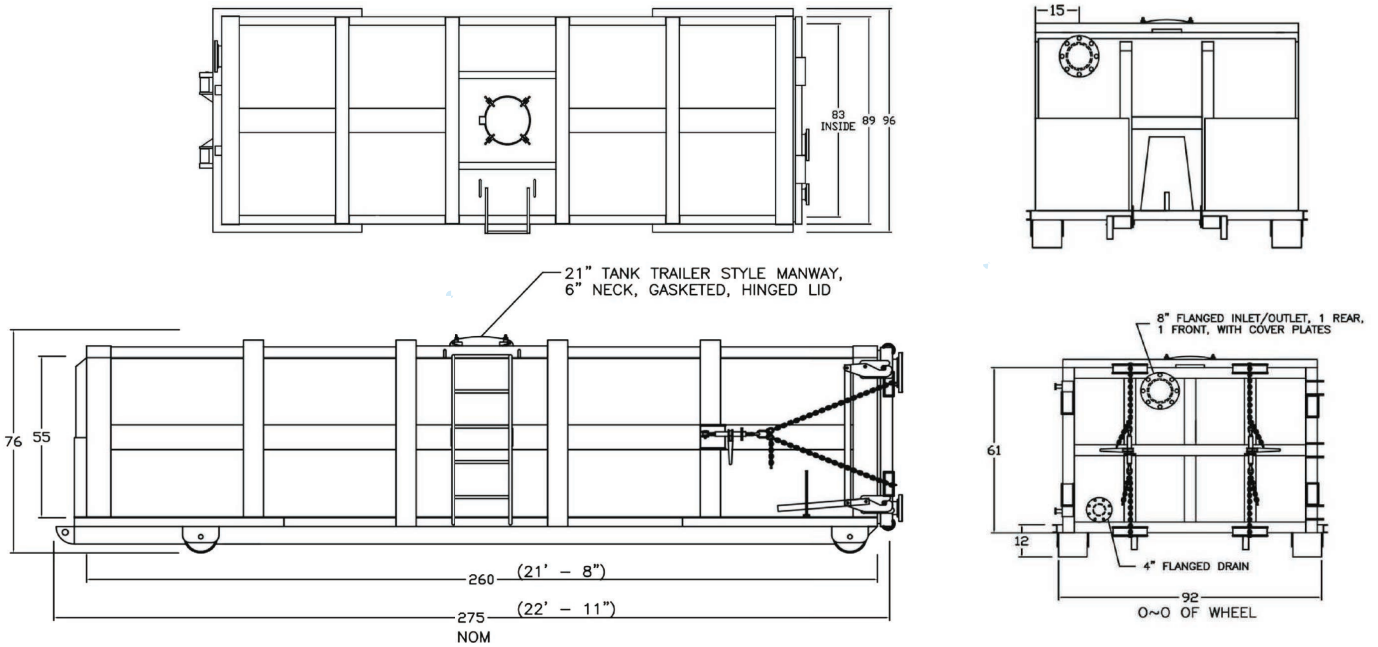

Dewatering Vacuum Box / 280-2520 Mechanical Dimensions

