



# 4" Vac Assist Sound Attenuated, Diesel-Driven Pump Package 104-1004

## Pump Specifications

Make	Cornell
Model	4NNT-EM16K-4 R-D
Size	4" x 4" (101.6 mm x 101.6 mm)
Impeller Diameter	10.09" (256 mm)
Impeller Type	Enclosed
Max Flow	1,200 gpm
Max Head	128 feet (39 meters)
Max. Operating Speed	1,800 rpm
Max. Operating Temp.	200 °F (93 °C)
Max. Operating Press.	200 psi (1,379 kPa)
Maximum Solid Size	3 inch

## Engine Specifications

FT4 Engine Type	Deutz D2.9L, 4-Cylinder Diesel
Displacement	177 cu. in. (2.9 l)
Fuel Consumption	2.07 gph (7.83 l/h) @ 1,800 rpm
Continuous HP	36 hp (27 kW) @ 1,800 rpm
Peak Intermittent HP Rating	49 hp (36 kW)
FT4 Specifics (Def or No Def, DOC, SCR, etc.)	DOC only. No DEF required.
Safety Shut-Down Switches	Low oil pressure, high temp
Instrument Panel	Oil pressure gauge, voltmeter, hourmeter, tachometer

## Priming System

Priming System	Diesel driven diaphragm-style vacuum pump
Air Removal Cap.	50 cfm (.02 cms)
Priming Chamber	Single chamber with positive sealing air separation PosiValve w/stainless steel float ball & linkage
Discharge Check Valve	Swing type, Ductile Iron, w/ Buna-N disc

## Features & Benefits

- Indefinite run-dry capability
- Extreme flow technology
- Environmentally safe priming system
- Auto-start controls
- Skid options available



## Package Specifications

Fuel Capacity	65 U.S. gallons
Control Panel	Controls Inc CX - Programmable Panel
Operating Speed (Max)	1,800 rpm
Weight (Dry/Wet)	4,550 / 4,960 lbs
Instrument Compatibility	High/low level floats, transducers
Trailer Brakes	Electric
Optional Adders	NTE automation

## Materials of Construction

Impeller	CA6NM Stainless Steel
Shaft	Stressproof Steel
Wear Ring	Cast Iron
Volute Casing	Cast Iron
Back-plate / Bearing	Cast Iron
Mechanical Seal	Cycloseal design. Tungsten vs. Silicon Carbide seal faces, Viton elastomers, 300 series stainless steel hardware & spring, seal system designed for dry running

## Enclosed Platform - DOT Trailer Mounted

Platform Material & Coatings	ASTM A36 Carbon Steel Material. Coated w/ metal primer & gloss enamel
Leveling Jacks	(1) 2,500 lb, Sidewind, Tongue Jack (2) 2,000 lb, Sidewind, Swivel Mount, Rear Stabilizing Jacks
Wheels & Tires	Radial Type - ST235-80R16 Single Tire Rating: 3.2k @ 80 psi Mounted to 15" Steel Wheel
Trailer Suspension	5,200 lbs. Strait Torsion Axle
Enclosure & Sound Attenuation	Powder-coated, galvaneal / Aluminium Enclosure panels & doors. 1.5" Sound Deadening Material. 70 dBA @ 25 ft



# 4" Vac Assist Sound Attenuated, Diesel-Driven Pump Package 104-1004

## Mechanical Dimensions

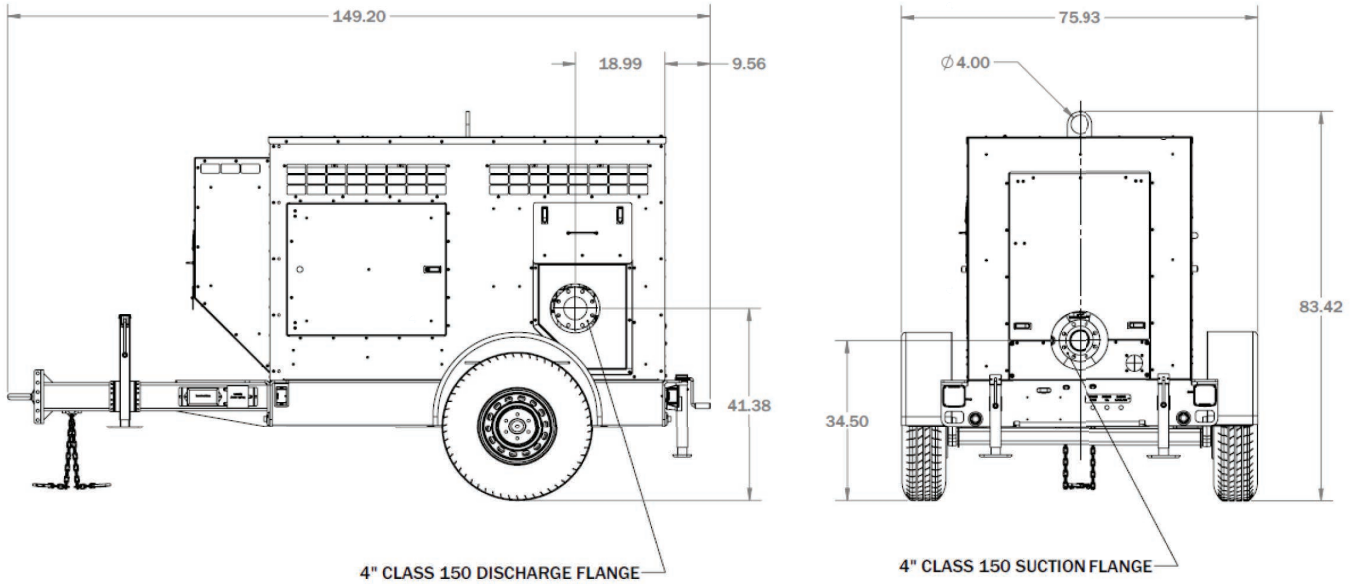

## Performance Curve

