



# 4" Vac Assist Diesel-Driven Centrifugal Pump Trailer Package 100-1004

## Pump Specifications

Make	Pioneer
Model	PP44S10
Size	4" x 4" (100 mm x 100 mm)
Impeller Diameter	10" (254 mm)
Impeller Type	Enclosed
Max Flow	1,520 gpm (345 m <sup>3</sup> /h)
Max Head	150 feet (50 meters)
Max. Operating Speed	2,200 rpm
Max. Operating Temp.	200 °F (93 °C)
Max. Operating Press.	260 psi (1,800 kPa)
Maximum Solid Size	3 inch (76 mm)

## Engine Specifications

FT4 Engine Type	Deutz D2.9L, 4-Cylinder Diesel
Displacement	177 cu. in. (2.9 l)
Fuel Consumption	2.07 gph (7.83 l/h) @ 1,800 rpm
Continuous HP	36 hp (27kW) @ 1,800 rpm
Peak Intermittent HP Rating	49 hp (36 kW)
FT4 Specifics (Def or No Def, DOC, SCR, etc.)	DOC
Safety Shut-Down Switches	Low oil pressure, high temp
Instrument Panel	Oil pressure gauge, voltmeter, hourmeter, tachometer

## Priming System

Priming System	Mechanically driven diaphragm-style vacuum pump
Air Removal Cap.	50 cfm (.02 cms)
Priming Chamber	Positive sealing air separation w/stainless steel components
Discharge Check Valve	Swing style; ductile iron w/nitrile disc Oil-lubricated mech seal allows pump to run completely dry without damage



## Features & Benefits

- Indefinite run-dry capability
- Extreme flow technology
- Environmentally safe priming system
- Auto-start controls
- Skid options available

## Package Specifications

Fuel Capacity	75 U.S. gallons
Control Panel	Controls Inc CX - Programmable Panel
Operating Speed (Min/Max)	1,200 / 2,200 rpm
Weight (Dry/Wet)	3,200 / 3,750 lbs
Instrument Compatibility	High/low level floats, transducers
Trailer Brakes	Electric
Optional Adders	NTE automation

## Materials of Construction

Impeller	CA6NM Stainless Steel
Shaft	17-4PH Stainless Steel
Wear Ring	ASTM A48 Class 40 Gray Iron
Suction Cover	Ductile Iron ASTM A536 65-45-12
Volute	Ductile Iron ASTM A536 65-45-12
Brac-plate/Bracket	Ductile Iron ASTM A536 65-45-12
Mechanical Seal	Silicon Carbide rotating and Tungsten Carbide stationary



# 4" Vac Assist Diesel-Driven Centrifugal Pump Trailer Package 100-1004

## Mechanical Dimensions

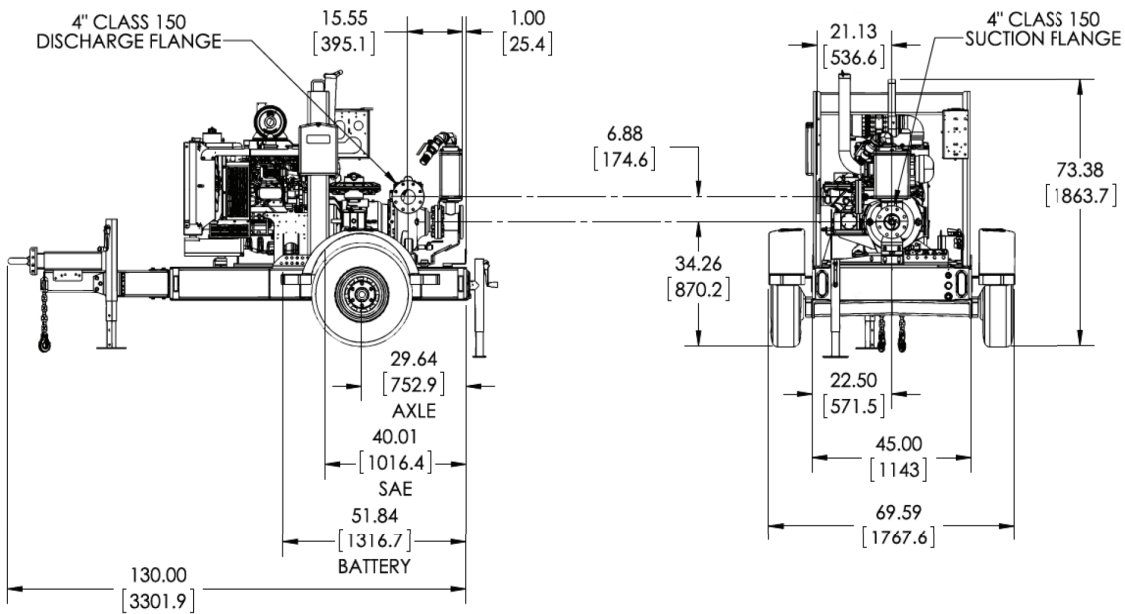

## Performance Curve

